

PNL-0606 SERIES

Application

LED panel light is designed to use for hotels, retail stores, factories, warehouses, restaurants, meeting rooms, museums, subways, healthcare facilities, living rooms, washrooms, corridors, and etc.

Specification

Input Voltage	200 ~ 240 V AC
Frequency	50 Hz
Power Factor	> 0.9
IP Rating	IP20
CRI	> 80
Beam Angle	110°
Light Efficiency	100 lm/W
Operating Temperature	-20°C ~ 40°C
Lifetime	> 50,000 hours
CCT	3000K, 4000K, 6500K
Housing	Aluminium Housing & Polycarbonate Diffuser
Mounting Method	Recessed/ Suspended/ Surface Mounted
Dimmable	Optional

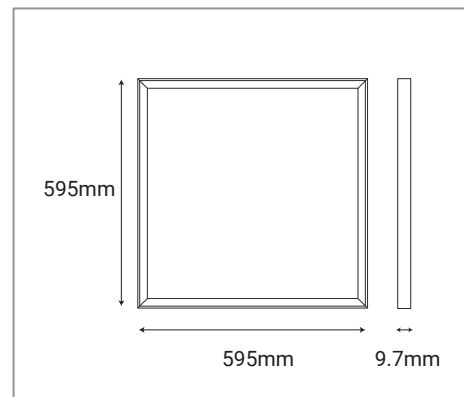

Ordering Data

Part No.	Power (W)	Lumens (lm)	CCT	UGR	Length (L x W x H)
EVO-RC-PNL-0606-36W-830	36	4104	3000K	< 19	595 x 595 x 9.7mm
EVO-RC-PNL-0606-36W-840	36	4320	4000K	< 19	595 x 595 x 9.7mm
EVO-RC-PNL-0606-36W-865	36	4320	6500K	< 19	595 x 595 x 9.7mm

Accessories



200-240V Driver
(Included accessory)



Safety Cable
(Included accessory)



Driver Holder
(Optional accessory)



Recessed Spring Kit
(Optional accessory)

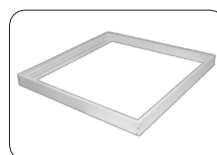

Surface Mounted Kit
(Optional accessory)

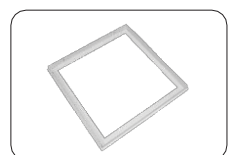

Gypsum Board Frame
(Optional accessory)

* Product specification subject to change according to technology improvement.