

## SPQ SERIES

### Application

LED Recessed Downlight is designed to use for homes, supermarkets, restaurants, commercial buildings & etc.

### Specification

<b>Input Voltage</b>	200 ~ 240 V AC
<b>Power Rating</b>	10W/ 15W/ 24W
<b>Frequency</b>	50 Hz
<b>Power Factor</b>	> 0.9
<b>THD</b>	< 20%
<b>CRI</b>	Ra > 80
<b>Beam Angle</b>	120°
<b>Max Operating Temperature</b>	45°C
<b>Lifetime</b>	> 50,000 hours
<b>Housing</b>	Die Cast Aluminium Housing & Polycarbonate Cover
<b>Mounting Method</b>	Recessed Ceiling Mounted
<b>IP Rating</b>	IP20

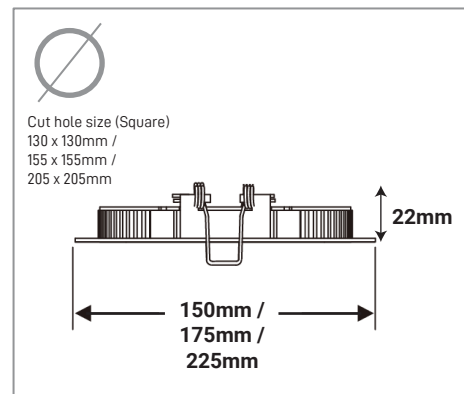

### Ordering Data

Part No.	Power (W)	Lumens (lm)	CCT
EVO-SPQ10W-150-6000K	10	1000	6000K
EVO-SPQ15W-175-6000K	15	1500	6000K
EVO-SPQ24W-225-6000K	24	2400	6000K
EVO-SPQ10W-150-4000K	10	950	4000K
EVO-SPQ15W-175-4000K	15	1425	4000K
EVO-SPQ24W-225-4000K	24	2280	4000K
EVO-SPQ10W-150-3000K	10	900	3000K
EVO-SPQ15W-175-3000K	15	1350	3000K
EVO-SPQ24W-225-3000K	24	2160	3000K

\* Product specification subject to change according to technology improvement.