

EVO-AN-ISSL-C-80W SERIES

Specification

LED	300/ 216pcs
Luminous Flux	150lm/w
LiFePO4 Battery	160WH
Mono Solar Panel	40W
Solar Charging Time	5 - 6 hours by bright sunlight
Lighting Time In Rainy Day	5 days
Lighting Mode	3hrs 100% + 2hrs 70% + 5hrs 50% + 2hrs 25% <i>(Can be customized based on customer needs)</i>
Material	Aluminium alloy + PMMA
IP Class	IP65
Work Temperature	0°C to 50°C

Features

- Imported LG 3030 LED Chips
Maximum brightness up to 150lm/W, 30% higher than similar products.
- Integral Die-cast Housing
High mechanical strength, up to 16 typhoon resistance.
- Adjustable Angle Lamp Arm
Can be used in 2 different types of lamp pole.
- Snap Type Battery Box Design
Convenient for battery and controller maintenance, save maintenance costs.
- Lamp Bead Types
Two different types of lamp beads to choose from.

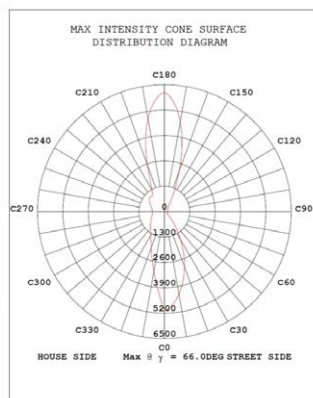
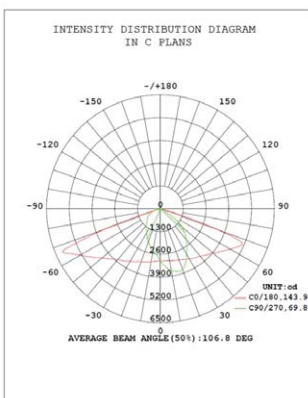
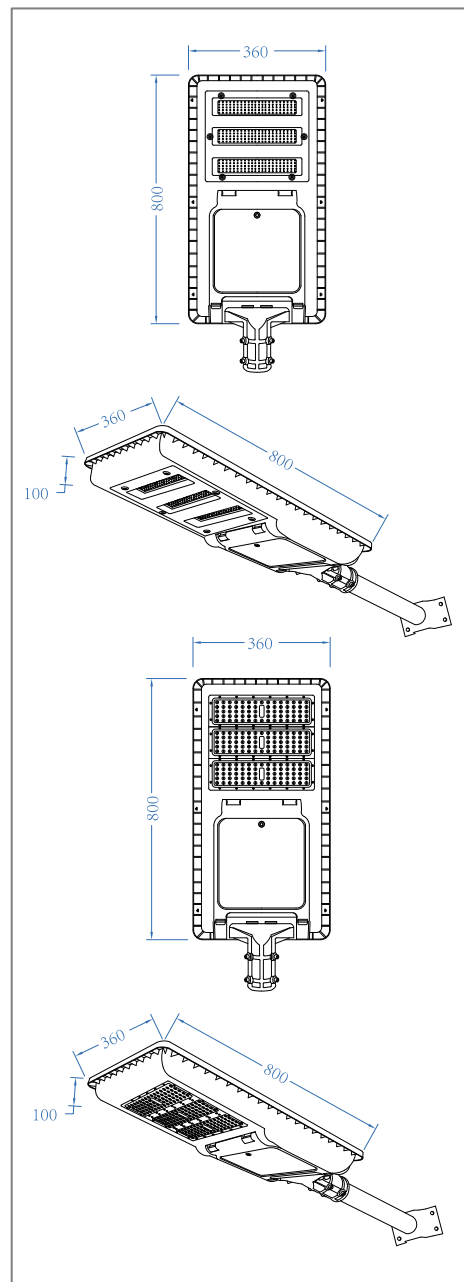

* Product specification subject to change according to technology improvement.