

SR02 SERIES

Application

Surface downlight is designed to use for office buildings, shopping centers, convenience stores, modern trade stores, discount stores, hotels, restaurants, residences, recreation centers, museums, etc.

Specification

Input Voltage	200-240 V AC
Power Factor	0.9 Typical
System Efficiency	50%
Operating Temperature	0 to 35 Degrees Celsius
Rendering Index	Min 80
Housing	Polycarbonate Housing & Mounting Base Polycarbonate Opal Diffuser
LED Operating Life	30,000 Hrs
Dimmable	Yes

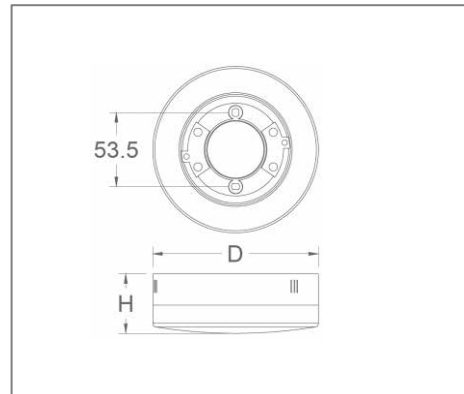

Ordering Data

Part No.	Power	Lumen	CCT (K)	Beam Angle	Dimension (mm)
EVO-SR-302	7W	700lm	3000K	110°	88 (D) x 43 (H)
EVO-SR-402	12W	1050lm	4000K		120 (D) x 43 (H)
EVO-SR-602	18W	1800lm	6000K		155 (D) x 43 (H)



* Product specification subject to change according to technology improvement.