

SG-UFO-A200W

Application

It can be widely used in warehouse, workshop, supermarket, logistic center, indoor stadium light etc.

Features

- Integrated housing design with low glare, perfect replacement of traditional MH high bay
- Rotating Carving Technology Housing, 1070 pure AL with thermal conductivity 236W/m*25°C
- High strength PC lens, IK 08, Anti-UV, transmittance > 94%
- Multiple lighting distributions: 60° / 90° / 110°
- Top brand LED chip and driver, ensure the product quality and lifetime
- Ingress Protection Rating: IP65
- Operation Temperature: -35° ~ +50°
- Luminous efficacy up to 150lm/W & 170lm/W

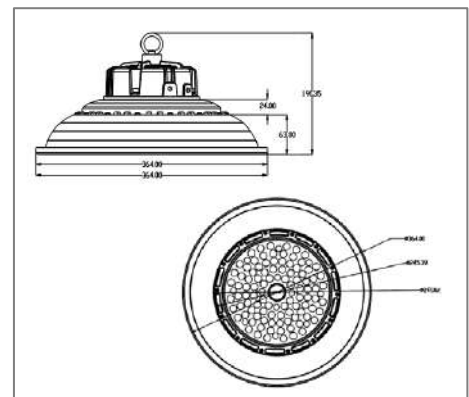

Specifications

Rated Power	200W
Input Voltage	AC85 ~ 265V / AC100 ~ 277V
Chip	Lumileds / OSRAM
CRI	Ra>70, Ra>80
Power Factor	> 0.95
Light Efficacy	Up to 150lm/W
IP Rating	IP66
Working Temperature	-35° ~ +50°
Beam Angle	60° / 90° / 110°
Warranty	5 years
Dimension	364*192mm
Certificate	CCC / CQC / TUV / CB / FCC / SAA / CE / RoHS / ETL

Photometry

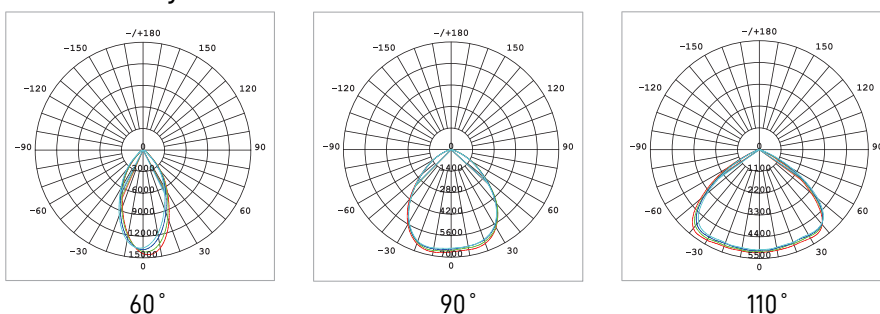

* Product specification subject to change according to technology improvement.