

FLTG200 SERIES

Application

Flood light is designed to use for compound lighting at office buildings, shopping centers, convenience stores, modern trade stores, hotels, residences, recreation centers, museums, signage, billboard etc.

Specification

| | |
|------------------------------|---------------------------|
| Input Voltage | 200-240 V AC |
| Power Factor | 0.9 Typical |
| System Efficiency | 89% |
| Rendering Index | Min 80 |
| Operating Temperature | -20 to 50 Degrees Celsius |
| LED Operating Life | 50,000 Hrs |
| Dimmable | Optional |
| Driver | Built-in |

Ordering Data

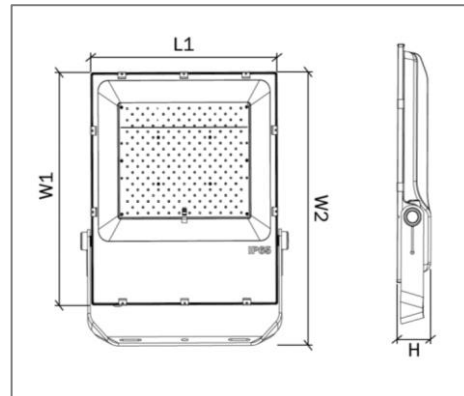

| Part No. | Power | Lumens | CCT (K) | Dimension | IP Rating |
|--------------------|-------|---------|---------|--|-----------|
| EVO-FL-TG200-NL-30 | 200W | 16643lm | 3000K | 360(L1) x 400(W1) x 470.25(W2) x 60(H) | IP65 |
| EVO-FL-TG200-NL-40 | | 18724lm | 4000K | | |
| EVO-FL-TG200-NL-57 | | 20804lm | 6000K | | |

* Product specification subject to change according to technology improvement.