

LD-1715

Application

LED Strip Light is designed to use for ceiling cove lighting, furniture lighting, indirect lighting and etc.



Specification

Mounting Method Recessed Mount / Surface Mount

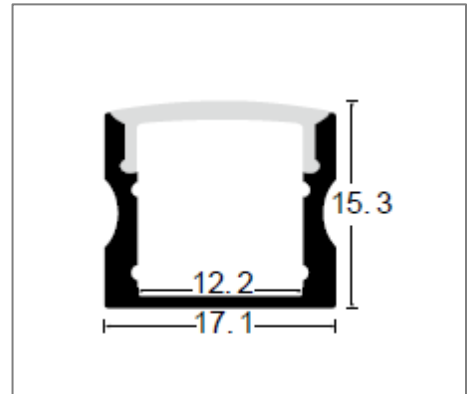

Accessories



Ordering Data

Part No.	LED Quantity (LEDs/M)	LED Strip Width (mm)	Wattage
EVO-LD-1715	> 182	< 10mm	< 16W/M

Related Product : Applicable with digital catalogue only
 (Please click the product photo to redirect towards the respective cut-sheet)

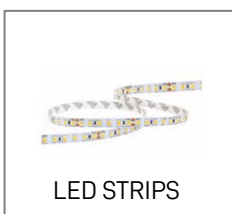

* Product specification subject to change according to technology improvement.