

HP90-S1 SERIES

Application

Pendant light is designed to use for office buildings, shopping centers, convenience stores, modern trade stores, discount stores, hotels, restaurants, residences, recreation centers, museums, etc.



Specification

Input Voltage	220-240 V AC /100-240 V AC
Frequency	50/60Hz
Lumen	80-100 lm/W
CRI	> 80/90
Color Finish	White / Black
Dim Option	Optional
IP Rating	IP 20

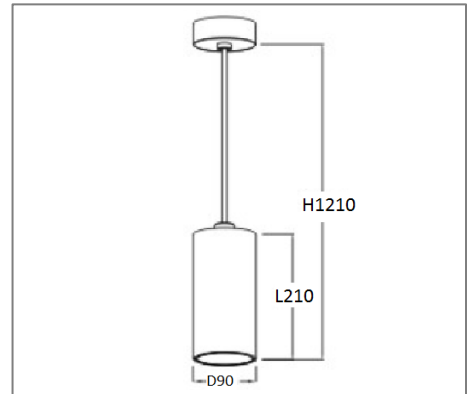

Ordering Data

Part No.	Power	Beam Angle	CCT
EVO-HP90-S1-S-20W-27	20W	15°/24°/38°/60°	2700K
EVO-HP90-S1-S-20W-30	20W	15°/24°/38°/60°	3000K
EVO-HP90-S1-S-20W-40	20W	15°/24°/38°/60°	4000K
EVO-HP90-S1-S-20W-50	20W	15°/24°/38°/60°	5000K
EVO-HP90-S1-S-30W-27	30W	15°/24°/38°/60°	2700K
EVO-HP90-S1-S-30W-30	30W	15°/24°/38°/60°	3000K
EVO-HP90-S1-S-30W-40	30W	15°/24°/38°/60°	4000K
EVO-HP90-S1-S-30W-50	30W	15°/24°/38°/60°	5000K

Remark: S= Suspended..