

LTS01 SERIES

Application

Surface Track Light is designed to use for office buildings, shopping centers, convenience stores, modern trade stores, discount stores, hotels, restaurants, residences, recreation centers, museums, etc.

Specification

Input Voltage	220 V AC 50Hz
Mounting Method	Surface Mounted
Housing	Extruded Aluminium with Copper Wire for 15A

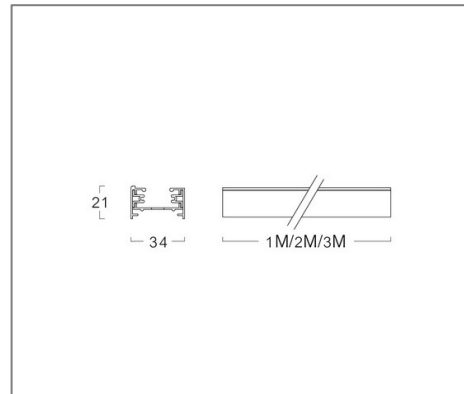

Ordering Data

Part No.	Description	Colour
EVO-LTS01-TR1-W	Surface Track 1 M	White
EVO-LTS01-TR2-W	Surface Track 2 M	White
EVO-LTS01-TR3-W	Surface Track 3 M	White
EVO-LTS01-TR1-B	Surface Track 1 M	Black
EVO-LTS01-TR2-B	Surface Track 2 M	Black
EVO-LTS01-TR3-B	Surface Track 3 M	Black
EVO-LTS01-ICT-W	I Connector	White
EVO-LTS01-ICT-B	I Connector	Black
EVO-LTS01-LCT-W	L Connector	White
EVO-LTS01-LCT-B	L Connector	Black
EVO-LTS01-PSC-W	Power supply w/ End cap Connector	White
EVO-LTS01-PSC-B	Power supply w/ End cap Connector	Black
EVO-LTS01-TCT-W	T Connector	White
EVO-LTS01-TCT-B	T Connector	Black
EVO-LTS01-XCT-W	X Connector	White
EVO-LTS01-XCT-B	X Connector	Black

Related Product : Applicable with digital catalogue only
 (Please click the product photo to redirect towards the respective cut-sheet)



* Product specification subject to change according to technology improvement.