

E-LS5070 SERIES

Application

Suspended Linear Light is designed to use for office buildings, shopping centers, convenience stores, modern trade stores, discount stores, hotels, restaurants, residences, recreation centers, museums, etc.

Specification

Input Voltage	200-240 V AC
IP Rating	IP20
Rendering Index	> 90
Lumen Per Watt	130lm/w
LED Operating Life	>50, 000 Hrs
Colour Correlated Temperature	3000K, 4000K, 6500K
Available Colour	White/Black/Grey
Beam Angle	120°
Dimmable	Optional
Mounting Method	Suspended Mounted

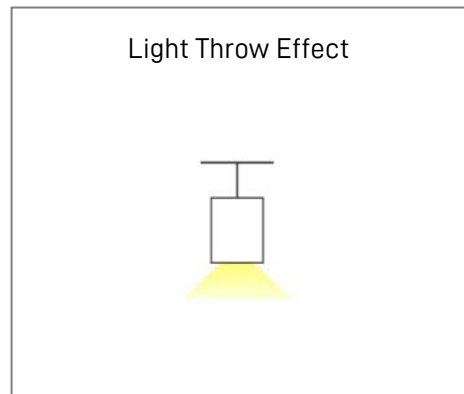
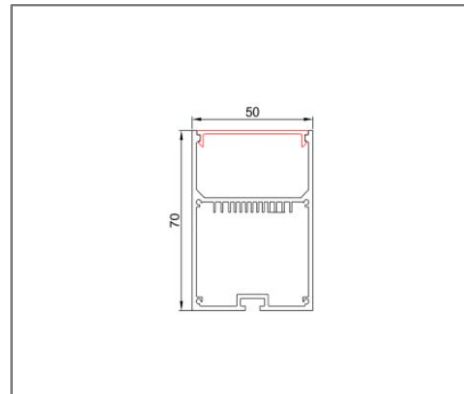
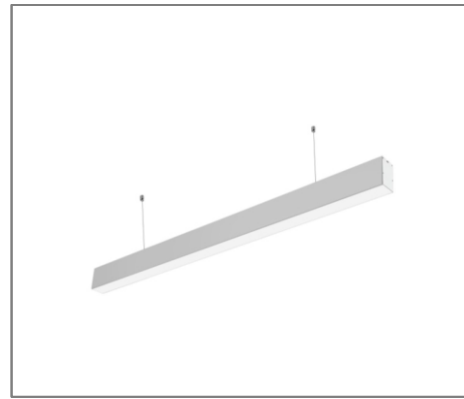

Ordering Data

Part No.	Power	Length (L x W x H)
EVO-E-LS5070-18W	18W	606mm x 50mm x 70mm
EVO-E-LS5070-36W	36W	1206mm x 50mm x 70mm
EVO-E-LS5070-54W	54W	1806mm x 50mm x 70mm
EVO-E-LS5070-72W	72W	2406mm x 50mm x 70mm