

SS01 SERIES

Application

Surface downlight is designed to use for office buildings, shopping centers, convenience stores, modern trade stores, discount stores, hotels, restaurants, residences, recreation centers, museums, etc.

Specification

Input Voltage	200-240 V AC
Power Factor	0.9 Typical
System Efficiency	89%
Operating Temperature	0 to 35 Degrees Celsius
Rendering Index	Min 80
Housing	Aluminium (Matt White) Polycarbonate Body & Opal Diffuser Electrostatically Polyester Powder Coated Flex & Nylon Connecting Devices
LED Operating Life	30,000 Hrs
Dimmable	No

Ordering Data

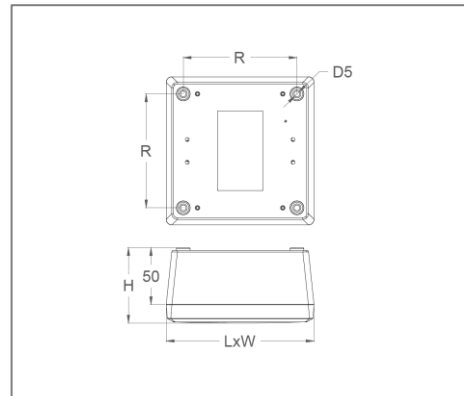
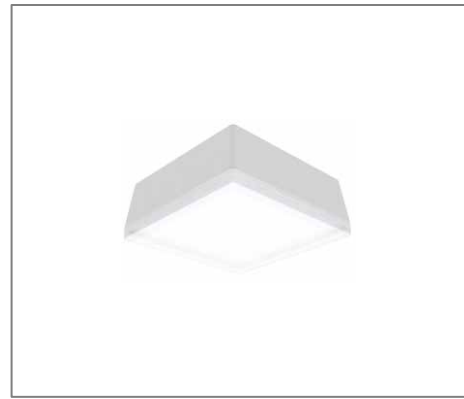

Part No.	Power	Lumen	CCT (K)	Beam Angle	Dimension (mm)
EVO-SS-301	10W	1000lm	3000K 4000K 6000K	120°	110 (LxW) x 66 (H) x 80 (R)
EVO-SS-401	15W	1500lm			130 (LxW) x 66 (H) x 100 (R)
EVO-SS-601	20W	2000lm			159 (LxW) x 66 (H) x 120 (R)
EVO-SS-801	24W	2400lm			178 (LxW) x 66 (H) x 135 (R)

* Product specification subject to change according to technology improvement.